

# NOW HEAR THIS!

THE NEWSLETTER OF THE KNOXVILLE POWER SQUADRON  
A Unit of the United States Power Squadrons  
Sail and Power Boating

District 17 of the United States Power Squadrons®

Vol. 23, No. 9

Sept 2011

## KPS BRIDGE

### Commander:

Cdr Margaret Edidin, P  
(865) 980-2840

### Executive Officer:

P/D/C Mike Scher, AP  
(865) 405-5512

### Squadron Education Officer:

Lt/C Tom Dietrich, SN  
(865) 657-9190

### Administrative Officer:

Lt/C Linda Ferrell  
(865) 531-3354  
lakelou1@yahoo.com

### Secretary:

Lt/C Rosemary Nicolaysen  
(865) 921-0199

### Treasurer:

Lt/C Maureen Hill  
(256) 997-7120

### Executive Committee:

Current Bridge plus  
P/C Henry (Hank) Davis, AP  
(865) 670-3698  
P/C James Barkley, SN  
(865) 966-7261  
Larry Lanz, P  
(865) 856-3062  
Bob Cadieux, AP  
(865) 981-9975

### Newsletter Editors:

Mary Cadieux, AP  
Ken Bloomfield, P  
(865) 293-2174  
khtb@bellsouth.net

## Commander's Comments

Cdr Margaret Edidin, P

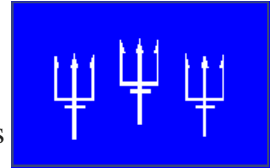

Eva and Ron Stob have retired as the editors of our newsletter. They produced 39 "Now Hear This" issues and won multiple national recognition awards from USPS for their outstanding work. They managed to do all this while traveling extensively, using their computer and local office stores for editing and distribution. Join me in thanking them for all of their time and effort over the last 3+ years and wishing them well as they sell their house and move to Colorado to be closer to their children.

This month's newsletter is the first to be produced by our new "Now Hear This" editors Ken Bloomfield and Mary Cadieux. Both of these individuals volunteered very quickly and decided to work together. Our newsletter is essential for good communication within the squadron and I am positive that its publication is again in good hands. Thank you Ken and Mary!

Many of our members enjoyed the August 13<sup>th</sup> Ice Cream Social at the Tellico Harbor clubhouse. A variety of ice cream flavors and other delicious desserts helped take some of the heat out of our very hot summer. It is always fun to catch up on how people are spending their summers. Tom and Marbeth Dietrich provided a special treat by sharing pictures from their recent boating trip in the Alaskan waters.

I did not attend the August 22<sup>nd</sup> dinner meeting, but Mike Scher reported that we had a good turn out and the food was good. There was also a very special guest in attendance... Mary Cadieux's father Lincoln who turns 100 years young next year on February 12<sup>th</sup>, along with another famous Lincoln.

Where was I on August 22<sup>nd</sup>? Well, Ira and I, plus my sister Melissa and

*(Commander's Report Continued on page 4)*



United States Power Squadrons  
America's Boating Club<sup>SM</sup>



## ELECTED NON-EXECUTIVE COMMITTEES

### AUDIT:

CHAIR: Janine Johnson  
2 Year: P/C Glenna Druif, P  
3 Year: P/C Hank Davis, AP

### NOMINATING:

CHAIR: Polly Lanz  
2 Year: Nancy Campbell, P  
3 Year: Vickie Smith, S

### RULES:

CHAIR: Chuck Q. Smith, S  
2 Year: Larry Nicolaysen, P  
3 Year: Rich Hawbaker, P

## PORT CAPTAINS

WATTS BAR LAKE: Robert McConnel, S/N FT LOUDOUN LAKE: P/C James C. Barkley, SN TELlico LAKE: P/D/C Mike Scher, AP

## APPOINTED COMMITTEE CHAIRS and OFFICERS (Some of the following positions will be updated.)

### BOAT SHOWS

### SAFETY

P/D/C Michael P. Scher, AP

### SQUADRON HISTORIAN

P/C Henry (Hank) Davis, AP

### LEGISLATIVE/LIASION

Chuck Q. Smith, S

### NEWSLETTER

Mary Cadieux, AP  
Ken Bloomfield, P

### MEMBERSHIP

P/D/C Ronald Lukens, AP

### PUBLIC RELATIONS

P/C Nick Tronolone, AP

### VESSEL SAFETY CHECK

Robert Bray, JN

### ROSTER

Connie Redmond

### WEBMASTER of KPS Website ([www.kps-site.org](http://www.kps-site.org))

Ken Bloomfield, P

### OPERATIONS TRAINING

P/D/C Ronald Lukens, AP

### LAW OFFICER

P/C James Barkley, SN

### PROPERTY OFFICER

Bob Bray, JN

### OPERATION BOAT SMART

Bob Bray, JN

### ASSISTANT SECRETARY

Nancy Campbell, P

## **The LUBBER LINE\***

This is the first issue of the "Now Hear This" Newsletter that Mary and I have created since taking over from Eva and Ron Stob. They passed over a very big set of shoes to fill!

We will likely take some time to really get up to speed on this process, but we will do our best. If you have any input for the Newsletter that you feel would be of interest to the membership, PLEASE send us that. We would love to have it, and it certainly makes our job easier when we have input. These "articles" can include anything that you think might be of interest to the members, and if you feel that you need help with the presentation, we can help. You can contact us as follows:

Mary Cadieux email: [marycadieux@mac.com](mailto:marycadieux@mac.com)

Ken Bloomfield email: [khtb@bellsouth.net](mailto:khtb@bellsouth.net)

*Are you getting your newsletter by email? If you aren't, you are reading a copy a few days later than need be. If you would like to begin receiving your newsletter by email, contact Ken Bloomfield at [khtb@bellsouth.net](mailto:khtb@bellsouth.net) or call 865-293-2174. Getting the newsletter by email instead of by regular mail means you get it a few days earlier, you can print it in vivid color which makes it more interesting to read, and it saves the squadron printing and mailing costs. If you have an address or email change, let the newsletter editors know at [khtb@bellsouth.net](mailto:khtb@bellsouth.net).*

*\*A lubber line, also called a lubber's line, a lubber's mark, and a lubber's point, is a reference mark on a compass or other navigational instrument indicating the heading of a vessel. We've created this lubber line to serve as our newsletter bulletin board to post pieces of information that effect our squadron's mark and direction.*



## August Ice Cream Social

I would like to thank every one who attended the Ice Cream Social and brought special goodies and home made ice cream. It was great and we had a good turnout.

## Upcoming Events — Mark your calendar!

### Salmon Roast - 25 September

We will not be having a regular dinner meeting in September. Instead we will be having a Salmon Roast. This year we are having the Salmon Roast at Lenoir City Park, Shelter 1. The address is City Park Drive, Lenoir City. This shelter is near the docks so if you would like to come by boat and tie up for the afternoon it would be easy to do. There will be a \$7.00 charge per person to cover the cost of the Salmon and we will collect at the dinner. We would like everyone to bring a side dish to share as well. We will be providing water, soft drinks, and coffee. Since we are having the dinner at the City Park, we may not be able to have alcoholic Beverages. We are looking into being able to have alcoholic drinks on Mike Scher's boat where we will be cooking the Salmon.



If you plan to ride on Mike's boat, he will be leaving Tellico Marina at 1100 and it takes about 2 hrs. To cruise to Lenoir City Park. If you are driving there, plan on meeting around 1400 and dinner at 1700.

Don't forget to get in touch with your calling committee member or you can call me and leave a message if you plan to attend so we will have an idea how much Salmon to purchase. We hope to see you there. My number is 865-531-3354 or by E-Mail [lakelou1@yahoo.com](mailto:lakelou1@yahoo.com).

### Fall Color Cruise - 22 October

There is no dinner meeting in Oct. The Fall Color Cruise is scheduled for Oct. 22 and planning on meeting at 11:30 for lunch at Tanssee Restaurant and after lunch taking a cruise up Tellico River to the Chilhowie Dam. If you would like to take your cruiser let us know how many passengers you can handle. Larger boats are welcome and can go up to the last marker. It should be a very nice cruise.



The next dinner meeting will be 14 November. The location will be in the next newsletter. I have asked Marbeth and Tom Dietrich to do a presentation about their trip to Alaska so I do hope everyone can attend.

### December Holiday Gala



This year the Holiday Gala will be 8 December at Sullivan's located at 121 W. Broadway, Maryville. We will have a menu and exact time in our upcoming newsletters.

### UPCOMING DIXIE DISTRICT FALL CONFERENCE

The MainStay Suites® hotel is perfectly located on a 25-acre farm, complemented by a stream running in front of the property plus an amazing view of the **Great Smoky Mountains National Park**.



The following people passed the July “ABC” class. Please welcome Thomas and Brooke Stakowiak as our newest members. Eight people came to the anchoring seminar. Most of the participants were new boaters so we focused on the needs of how to anchor on the lake.



- We will be teaching a Seamanship class and an Advanced Piloting class this fall. The Seamanship course is a natural first/next step in building a foundation for confidence and competence for safe and enjoyable boating on the water. It extends the knowledge and skills of the boater in handling and maneuvering a vessel, either sail or power. The course provides a better understanding of how boats behave under various conditions including close quarters and open water operations. Knowledge and skills are increased in the areas of anchoring, emergencies, rules of the road, and marlinspike/basic knots.
- Advanced Piloting is the second in the sequence of USPS courses on navigation. It continues to build coastal and inland navigation skill, allowing the student to take on more challenging conditions – unfamiliar waters, limited visibility, and extended cruises. GPS is embraced as a primary navigation tool while adding radar, chartplotters, and other electronic navigation tools. As with Piloting, the course includes many in-class exercises, advancing the student’s skills through hands-on practice and learning.

The classes will start in late October and run 4 to 5 weeks. Anyone interested in attending please contact Tom Dietrich at [tdietric1@aol.com](mailto:tdietric1@aol.com). Remember you do not have to be a Squadron member to attend these classes, so if you know someone who is interested let them know about the class. Look for specific dates in the next news letter.

*(Commander’s Report Continued from page 1)*

brother-in-law Avie and my brother Skip and sister-in-law Sue, were busy treating our parents, Leonard and Mary Lane, to a trip to Chattanooga to celebrate their 70<sup>th</sup> wedding anniversary. We took in a show at the IMAX Theater and the aquariums. It was a very special day for all of us.

Congratulations go to Kathy Phillips for reaching her 25<sup>th</sup> anniversary of USPS membership. Kathy was one of the first female members and has also served as Commander of the Knoxville Power Squadron.

I have not yet received any feedback from USPS on our proposed bylaws. I sent an e-mail last week asking for an update.

Please check out the plans for our Sunday, September 25<sup>th</sup> Salmon Roast and Saturday, October 22<sup>nd</sup> Fall Color Cruise elsewhere in this newsletter. These events are always fun. I hope you will be able to attend. Please let your phone/e-mail committee contact person know if you will be able to attend so we can plan accordingly.

The District 17<sup>th</sup> Conference is October 28<sup>th</sup> thru October 30<sup>th</sup> at the Main Stay Hotel in Pigeon Forge at 410 Pine Mountain Road. You can make reservations for the hotel by calling 888-428-8350. Mention USPS District 17 to get the \$99 plus tax rate. You can also get a \$79 rate if you wish to stay at the hotel on the Wednesday or Thursday before the conference. Meals will be catered and will require pre-payment, but those details are still pending.

*(Commander’s Report Continued on page 5)*

*(Commander's Report Continued from page 4)*

Our squadron will be the host for this event which means we will need people to check people into the conference and staff the hospitality suite. Even if you cannot attend the whole conference, you are invited to attend whatever you can. If possible, it would be great if you could attend the Saturday night dinner. KPS will not have a dinner meeting in October.

We are still looking for someone to do some shopping for us. We would like to order more boating emergency whistles with our squadron name and website on them to give out at publicity events such as boat shows and to give to our ABC course graduates. We would like to get samples so we can be sure of the quality before actually purchasing them.

The Nominating Committee is still considering possible candidates for the 2012 Bridge, Executive Committee and other committee positions. Please let Polly Lanz, Nancy Campbell or Vickie Smith know if you have any interest in any of these positions or if you want to recommend anyone. The Nominating Committee may not know of people interests or skills unless YOU let them know. We really need your help on this.

### Boat for Sale

- 1987 Sea Ray 270 Sundancer
- 10 ft. beam, 33 ft LOA, 27' 7" center line
- Twin 260 HP gas I/O engines Actual Hours (1 Jul 2011):  
Port 208; Starboard; 268
- 4 KW Generator
- Fuel Capacity: 120 gal
- Fresh Water Capacity: 28 Gal
- Black Water Capacity: 40 gal
- Hot Water Heater
- Galley w/range, refrigerator
- Air Conditioner
- Head
- Sleeps 6

Price: Negotiable

**Contact: Bill Katterhenry; 941-504-1662; 111 Hiawassee Lane, Tellico Village**



### Canoe for Sale

16' Mohawk Blazer tandem canoe, white fiberglass, woven cane seats, gently used, nice condition. Includes 3 wood paddles and foam block carriers. A great little stable canoe. \$325/offer. Phone Ron Stob: 865-856-7888.

### Vol Navy and Boomsday – 3-4 September

**New Bridge, Same Big Boom:** For the first time in more than 24 years, Knoxville's annual Boomsday display, the largest Labor Day fireworks show in the nation, is moving to a new bridge. The fireworks will launch from the Railroad Bridge over the Tennessee River in downtown Knoxville on Sunday night, 4 September. According to Pyro Shows, the fireworks will be launched from train cars on the railroad bridge. Some of us take our boats to Volunteer Landing and anchor and/or raft-up for the entire weekend. The first University of Tennessee Volunteer home football game of 2011 takes place at 1800 on Saturday, 3 September, so go by boat early Saturday and be part of the Volunteer Navy. It's quite an experience. You don't even have to attend the game.

Those of you who were at the District conference in Nashville in March, might recall the terrific entertainment provided by the group Boat Jammers. This lively group write their own songs and all are based around what we so dearly love, Boats & Water. I wanted to make you aware that they have a new 15 song album out called, appropriately, The Boat Jammers. I have this terrific album and after you have heard it too, you'll probably want to place all your Jimmy Buffet albums on the back shelf and keep this one up front. You can hear clips from these songs on their website [www.boatjammers.com](http://www.boatjammers.com) Of course, you can place your order there, as well.

I hope you'll support them by spreading the word and buying the album wouldn't hurt either! After all, how often do you have the opportunity to have a musical group that is tuned in, specifically, to boating and is local.



Yours in Musical Boating,  
P/C Harold DeHart

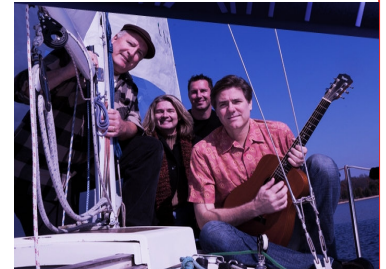

### Boat for Sale — 1997 Lakeview 16' X 73' + 3' Wide body

Still for sale: our 1997 76'x16 Lakeview, priced now at \$154,500. This is the direct link to see many exterior & interior photos: <http://www.houseboatsbuyterry.com/images/listings/deha/deha-out.htm>

Not desperate, but highly motivated. All offers considered!

Located at Terrace View Marina, Watts Bar Lake

Call cell # 256-572-1989

Twin 5.7 Liter Mercruiser's (Port-359 hrs.), (Starboard-357 hrs.), MMC Controls, 15 KW Westerbeke Generator (690 hrs.), 2500 Watt Inverter, Stern Thrusters, Dual VHF Marine Radio's, Depth Finder, GPS, 3 Ton Central Air & Heat (new 2009), Twin 50 Amp Shore Power, Roof Bar with Party Top, Hot Tub & Rope Lighting, Water Slide, Swim Platform, 3-80 Gallon Fuel Tanks (one w/PWC fuel pump), 2-80 Gallon Fresh Water Tanks, 4 Bedrooms (King Master, 2 Queens & 1 Twin), 2 Baths with Purasan Waste Treatment System, 4 TV's (3 Flat screens), 2 DVD Players, 2 VCR's, Surround Sound, CD & Cassette (top & lower), Fireplace w/heat, Full size stack washer/dryer, Leather reclining sofa & loveseat (new 2010) 6 chair dining set, Full size Range, Refrigerator, Dishwasher, Microwave & Ice Maker, 6 chair dining set, Stern Davit, Aft Lockers for Storage, Lots of Extras. Furnished, except for personal furniture, items and pictures (outlined at time of purchase).



This is the first of a series of technical discussions that hopefully will be of interest to some members. The cooling systems are often taken for granted, and they play an exceptionally important role in the health of your engine.

## Understanding the Importance of the Fresh Water Cooling Systems

The term "Fresh Water Cooling Systems" also known as "Closed Marine Cooling Systems" can be confusing as these systems circulate antifreeze and not water. Marine Fresh Water Cooling systems are similar to the cooling system in an automobile, however, rather than a radiator they utilize a heat exchanger and rather than using air to remove the heat generated by the engine they use lake or ocean water.



The heat exchangers are constructed by inserting a tube bundle of small tubes, maybe 150 or more, into a single large tube approximately 4" - 6" in diameter. The raw water pump on the engine flows sea water through the inside of the smaller tubes and makes multiple passes back and forth across the unit while removing the heat from the engine before finally exiting and flowing out the exhaust system. The anti-freeze or "jacket water" flows up and down across the outside of the smaller tubes in one single pass as it dispels the heat load of the engine into the raw water.

Engines With Raw Water Flow Thru Exhaust Manifolds

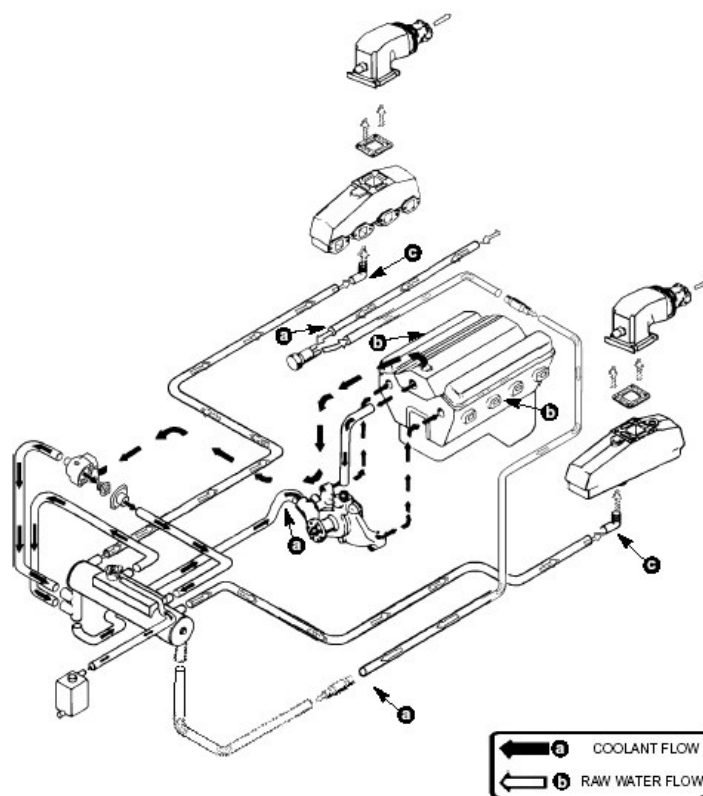

These systems are thought to be primarily reserved for people who operate in corrosive water conditions, however as you will see these systems have much more to offer than just corrosion protection. One of the main deficiencies of the standard "open" cooling systems is that they rely on a pressure balance for proper functioning. In extreme cases you can be introducing 40 degree water into the circulation loop that is attempting to regulate the engine at 160 degrees. This makes it near impossible for the engine to operate without some amount of cycling. Also with the onset of more stringent emissions regulations it is near impossible for the open systems to produce a stable enough operating condition that the engine spark and fuel mapping can be maximized.

Next month, we'll discuss the common denominator of both "Open" and closed marine cooling systems, that being the ubiquitous raw water impeller, and its care and keeping.



[www.kps-site.org](http://www.kps-site.org)

"We promote boating safety and enjoyment through education and camaraderie"



## UPCOMING EVENTS... (Details inside this or next issues.)

Tuesday, 13 September	1900	Bridge Meeting Ft. Loudoun Yacht Club
Monday-Saturday, 12-17 September		USPS National Board Meeting Greensboro, NC
Sunday, 25 September	TBA	Annual Salmon Roast Lenoir City Park, Shelter 1
Saturday, 22 October		Fall Color Cruise
Friday-Sunday, 28-30 October		Dixie District (17) Fall Conference MainStay Suites, Pigeon Forge
Monday, 14 November	1800	Dinner Meeting
Thursday, 8 December		Annual Holiday Gala

*Knoxville Power Squadron, Inc.*

**A Unit of United States Power Squadrons  
Sail and Power Boating**

Newsletter Editors  
Mary Cadieux and Ken Bloomfield  
1739 Arrowhead Blvd  
Maryville, TN 37801

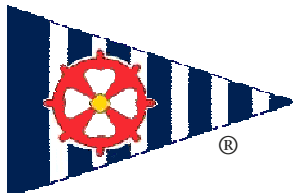

**USPS D-17 2011 FALL CONFERENCE PIGEON FORGE, TN**  
**MEAL RESERVATION FORM**

HOSTED BY THE KNOXVILLE POWER SQUADRON AT THE MAINSTAY SUITS, 410 PINE MOUNTAIN, TN 37863

Name (Print) \_\_\_\_\_  
Other in Party (Print) \_\_\_\_\_  
City, State, Zip \_\_\_\_\_  
Telephone \_\_\_\_\_ E-mail \_\_\_\_\_  
Affiliation (D-17 Squadron Name or Guest Organization) \_\_\_\_\_

**Friday Night, 28 October, 2011**

Dinner Barbeque Buffet: Includes two Entrees: (served on disposables) **Barbeque Chicken; Smoked Beef Brisket**. Included Accompaniments: Southern Potato Salad, Deviled Eggs, Corn-on-the-Cob, Molasses Baked Beans, Fresh Rolls or Buns, Appropriate Condiments.  
Desert: Apple Cobbler Drink: Ice Tea and Coffee \_\_\_\_\_ tickets@ \$17.00 ea = \_\_\_\_\_

**Saturday Lunch, 29 October, 2011**

Lunch Boxed Lunch: Choice of **“Chunky Chicken Salad Croissant”** + Potato Salad, Chips, Condiments and Chocolate Chip Cookie.

Drink: (D-17 to provide water & soft drinks) \_\_\_\_\_ tickets@ \$ 10.50 ea = \_\_\_\_\_

Or, **Ham or Turkey (circle one) on a Sourdough Roll** W/Lettuce, Tomato & Pickle, + Potato Salad, Chips. Condiments and Chocolate Chip Cookie.

Drink: (D-17 to provide water & soft drinks) \_\_\_\_\_ tickets@ \$ 10.50 ea = \_\_\_\_\_

**Saturday Night, 29 October, 2011**

Dinner Buffet: Includes Two Entrees, Two Salads, Two Side Dishes, Fresh Baked Rolls.

Drink: Coffee and Tea

Salads: Spinach, Feta Cheese, Shaved Onions, Mushrooms, Rosemary Vinaigrette; and, Golden Apple Slaw

Entrées: **Roasted Pork Loin**, Sauce (on the side): Apple Jack Cream

And, **Grilled Salmon**, Sauce (on the side): Lemon Caper

Side Dishes: Steamed Vegetables; Scalloped Potatoes

Desert: Peach Pie or Strawberry Cake

\_\_\_\_\_ tickets@ \$23.00 = \_\_\_\_\_

**TOTAL SUBMITTED = \$ \_\_\_\_\_**

**Note:** Dinner reservations must be received no later than October 14<sup>th</sup>, 2011. All meal costs are inclusive of tax and gratuity. **Make checks payable to “USPS District 17”. Mail check and this completed form to: C Margaret Edidin, P, 4620 Gravely Hills Rd., Louisville, TN 37777, Ph H 865-980-2840, C 865-771-2570 , e-mail [riverbreezetn@hotmail.com](mailto:riverbreezetn@hotmail.com).**

**BREAKFAST: COMPLIMENTARY DELUXE CONTINENTAL, INCLUDED DAILY!**